

應用範例 Application Example

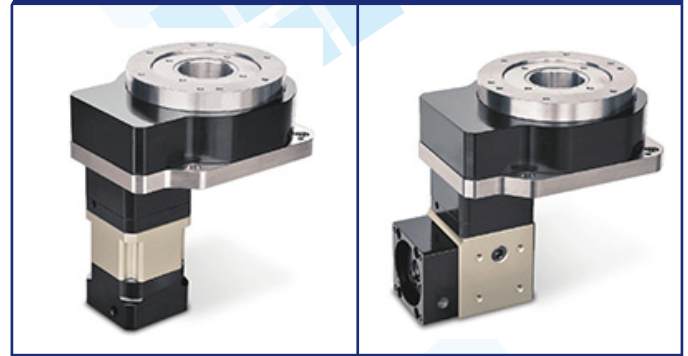

產品特性

- 工作物可直接鎖固
旋轉盤面可直接鎖固工作物，提升工作裝載之方便性。
- 配線方便
此旋轉平台為中空式設計，無論是配線或配管均方便。
- 高精度
定位精度小於一分，重複精度可達 ± 5 秒。
- 運轉動作平穩
盤面轉動平穩、順暢，且定位快速。
- 適用馬達
中空旋轉平台可採用各種廠牌之伺服馬達或步進馬達驅動。
- Direct Mounting of Workpiece
The rotating table allows for direct mounting of workpiece for added convenience in workpiece loading.
- Convenient Wiring
The rotating table is a hollow structure design, making it convenient for electric or piping work.
- High Accuracy
Positioning accuracy is less than 1min, Repeatability may reach ± 5 sec.
- Stable Rotating Motion
The table rotation is stable and smooth as well as fast in positioning.
- Suitable for Various Motors
The rotating table can be driven by various brands of servo motors or stepping motors.



性能數據 Performance data

Type	Unit	60型步進馬達	200~400W AC伺服馬達
旋轉平台軸承 Bearings of rotating table	-	圓錐滾子軸承 Taper roller bearing	
容許轉矩 Permissible torque	N·m	20	
慣性慣量 Moment of inertia	Kg.m ²	9216×10 ⁻⁶	
允許轉速 Permissible speed	Rpm	200(盤面disk)	
解析度P/R Resolution P/R	-	半步進設定~微步進設定 8,000~1500,000	依伺服馬達規格
減速比 Speed reduction ratio	-	直結式減速機1:10	直角減速機 1:20
定位精度 Positioning accuracy	Mins	≤1	
反覆定位精度 Repeatability	sec	±5	
容許推力載重 Permissible thrust force	kgf	250	
容許慣性載重 Permissible load of inertia	N.m	60	
旋轉平台平行度 Permissible of rotating table	mm	±2	
旋轉平台同心度 Concentricity of rotating table	mm	≡ 0.01	
保護等級 Protection class	IP	40	
重量 Weight	Kg	5.5	

- 特殊規格歡迎來電洽詢訂製。Please contact us of inquiries regarding other Specifications.
- 訂購時請提供馬達法蘭尺寸。Please provide moter flange size wghen ordering.



UNIT: mm

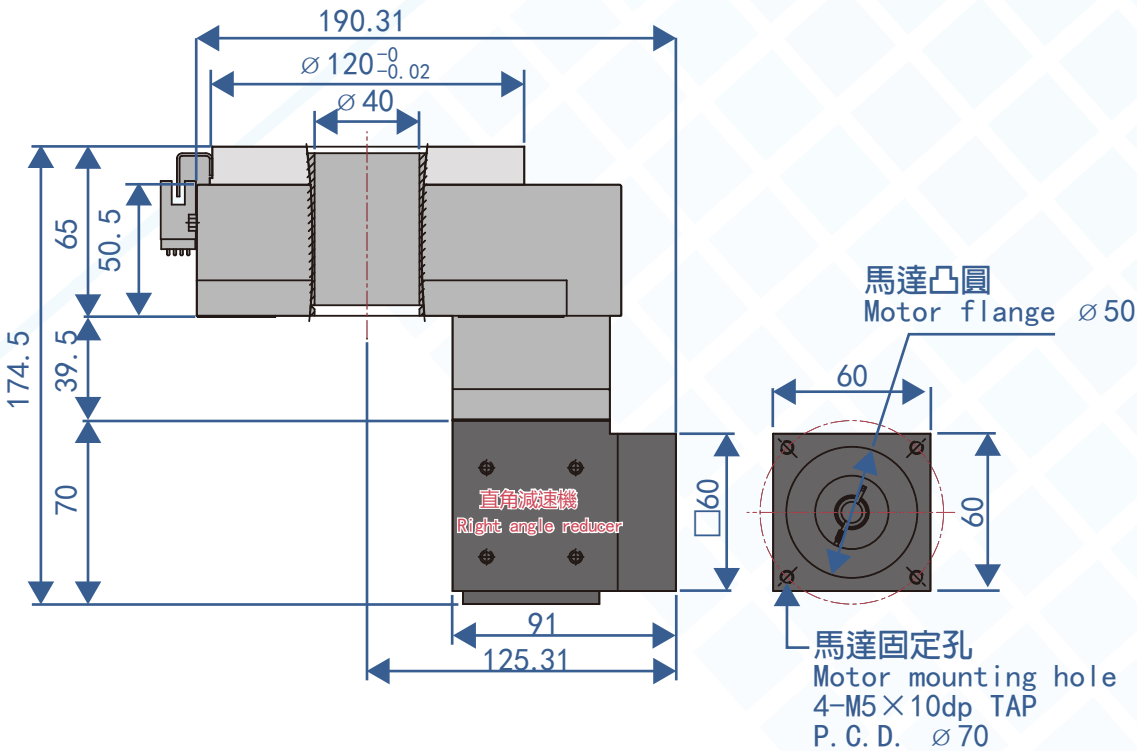
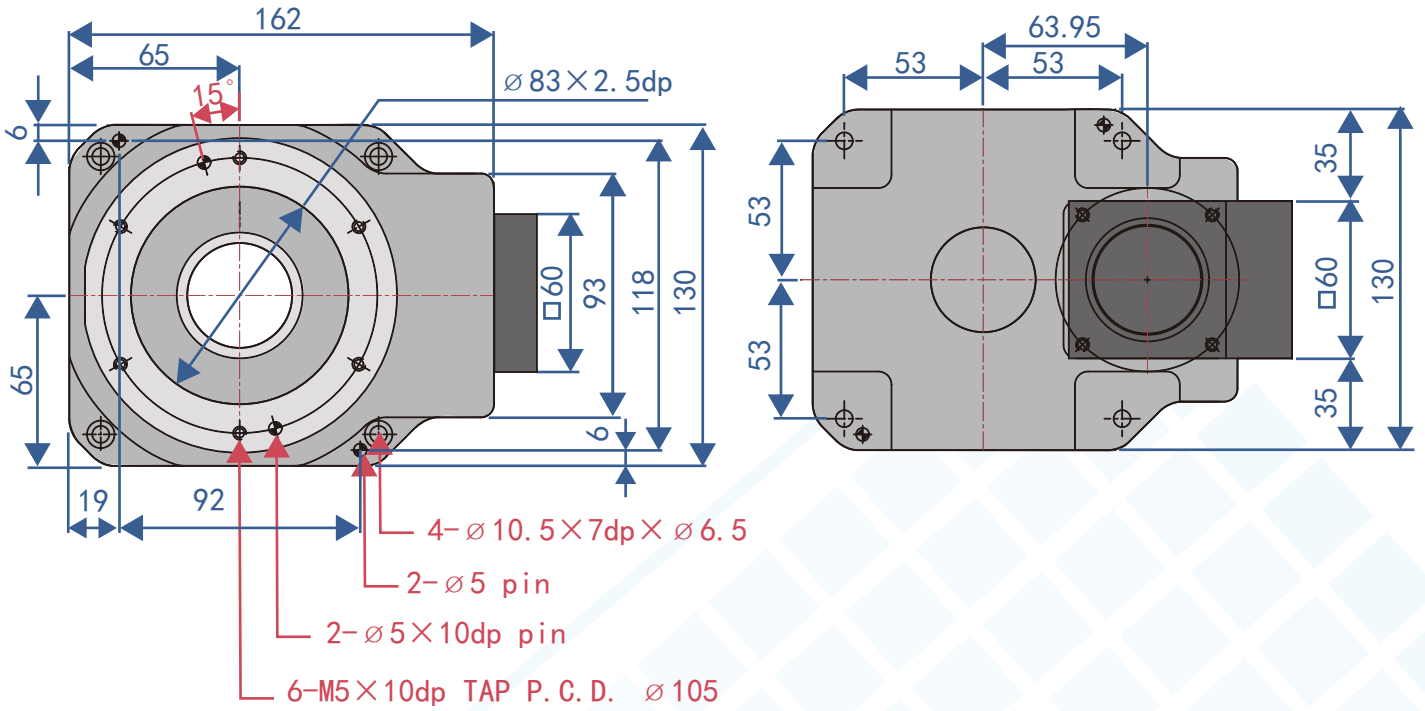

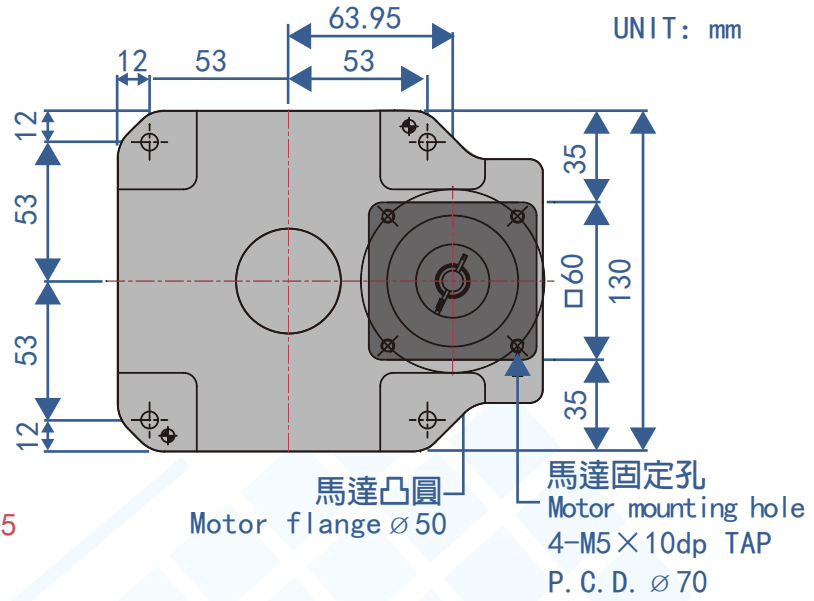
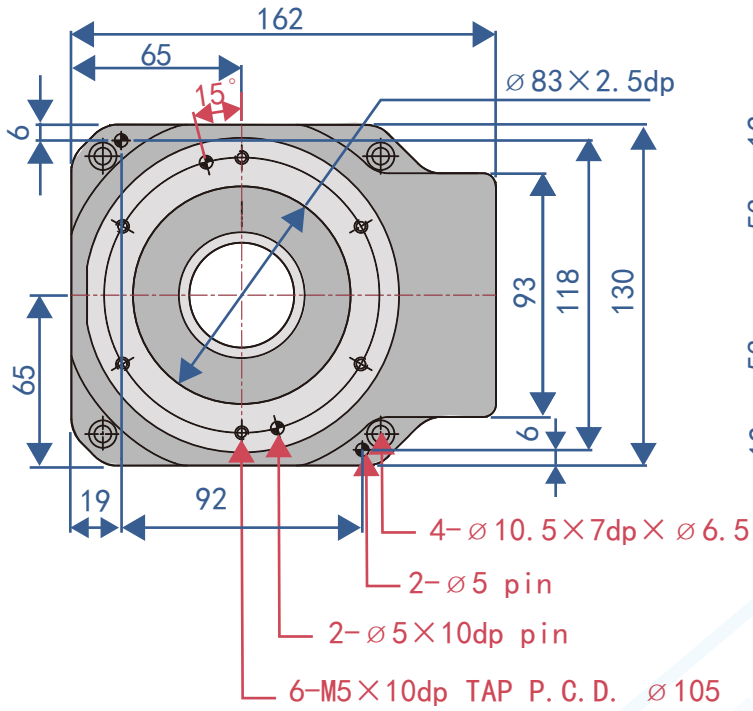

UNIT: mm

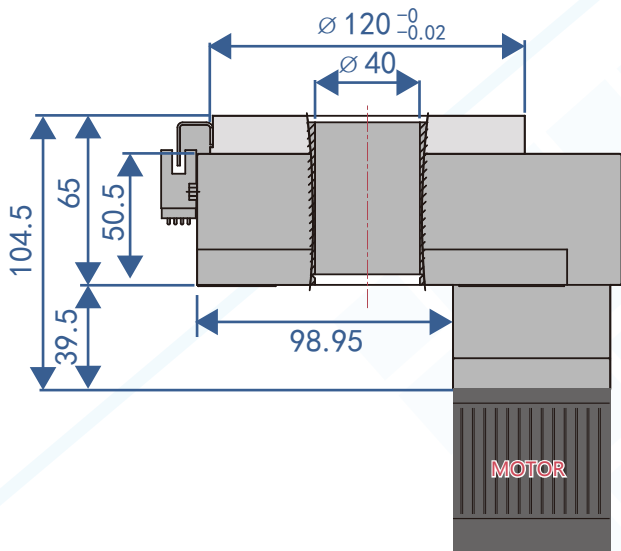

60型步進馬達定置 減速比=1:30

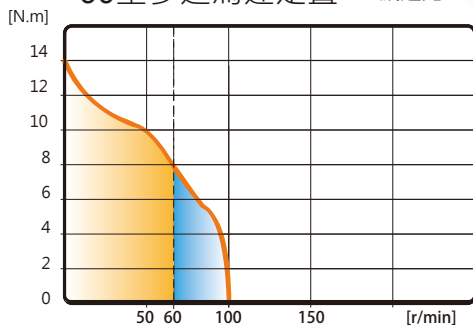

適用載重轉速領域
Applicable Load Speed field
慣量輕載領域
Field light load inertia

200-400w伺服馬達定置 減速比=1:30

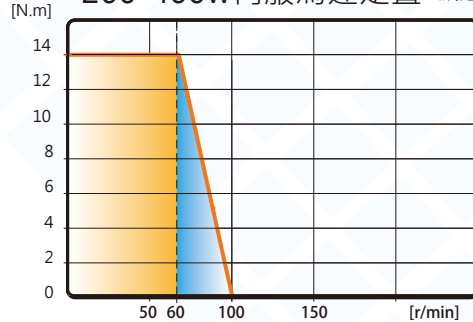

適用載重轉速領域
Applicable Load Speed field
慣量輕載領域
Field light load inertia