

應用範例 Application Example

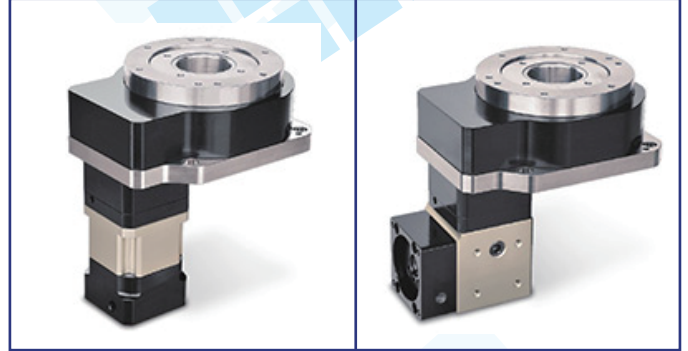

產品特性

- 工作物可直接鎖固
旋轉盤面可直接鎖固工作物，提升工作裝載之方便性。
- 配線方便
此旋轉平台為中空式設計，無論是配線或配管均方便。
- 高精度
定位精度小於一分，重複精度可達 ± 5 秒。
- 運轉動作平穩
盤面轉動平穩、順暢，且定位快速。
- 適用馬達
中空旋轉平台可採用各種廠牌之伺服馬達或步進馬達驅動。
- Direct Mounting of Workpiece
The rotating table allows for direct mounting of workpiece for added convenience in workpiece loading.
- Convenient Wiring
The rotating table is a hollow structure design, making it convenient for electric or piping work.
- High Accuracy
Positioning accuracy is less than 1min, Repeatability may reach ± 5 sec.
- Stable Rotating Motion
The table rotation is stable and smooth as well as fast in positioning.
- Suitable for Various Motors
The rotating table can be driven by various brands of servo motors or stepping motors.



性能數據 Performance data

Type	Unit	85型步進馬達	750W AC伺服馬達
旋轉平台軸承 Bearings of rotating table	-	圓錐滾子軸承 Taper roller bearing	
容許轉矩 Permissible torque	N·m	65	
慣性慣量 Moment of inertia	Kg.m ²	111279×10 ⁻⁶	
允許轉速 Permissible speed	Rpm	200(盤面disk)	
解析度P/R Resolution P/R	-	半步進設定~微步進設定 10,000~1800,000	依伺服馬達規格
減速比 Speed reduction ratio	-	直結式減速機1:10	直角減速機 1:20/1:30
定位精度 Positioning accuracy	Mins	≤1	
反覆定位精度 Repeatability	sec	±5	
容許推力載重 Permissible thrust force	kgf	800	
容許慣性載重 Permissible load of inertia	N.m	200	
旋轉平台平行度 Permissible of rotating table	mm	±2	
旋轉平台同心度 Concentricity of rotating table	mm	≡ 0.01	
保護等級 Protection class	IP	40	
重量 Weight	Kg	19	

- 特殊規格歡迎來電洽詢訂製。Please contact us of inquiries regarding other Specifications.
- 訂購時請提供馬達法蘭尺寸。Please provide moter flange size wghen ordering.



UNIT: mm

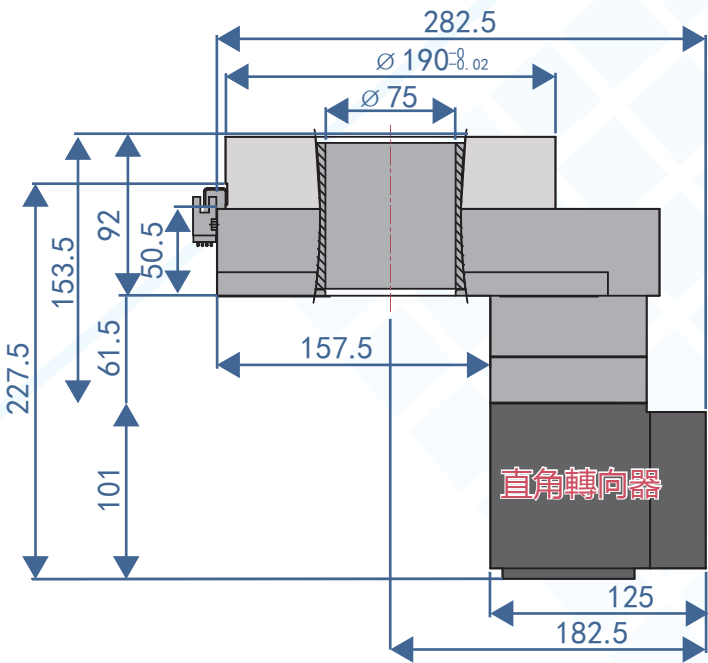
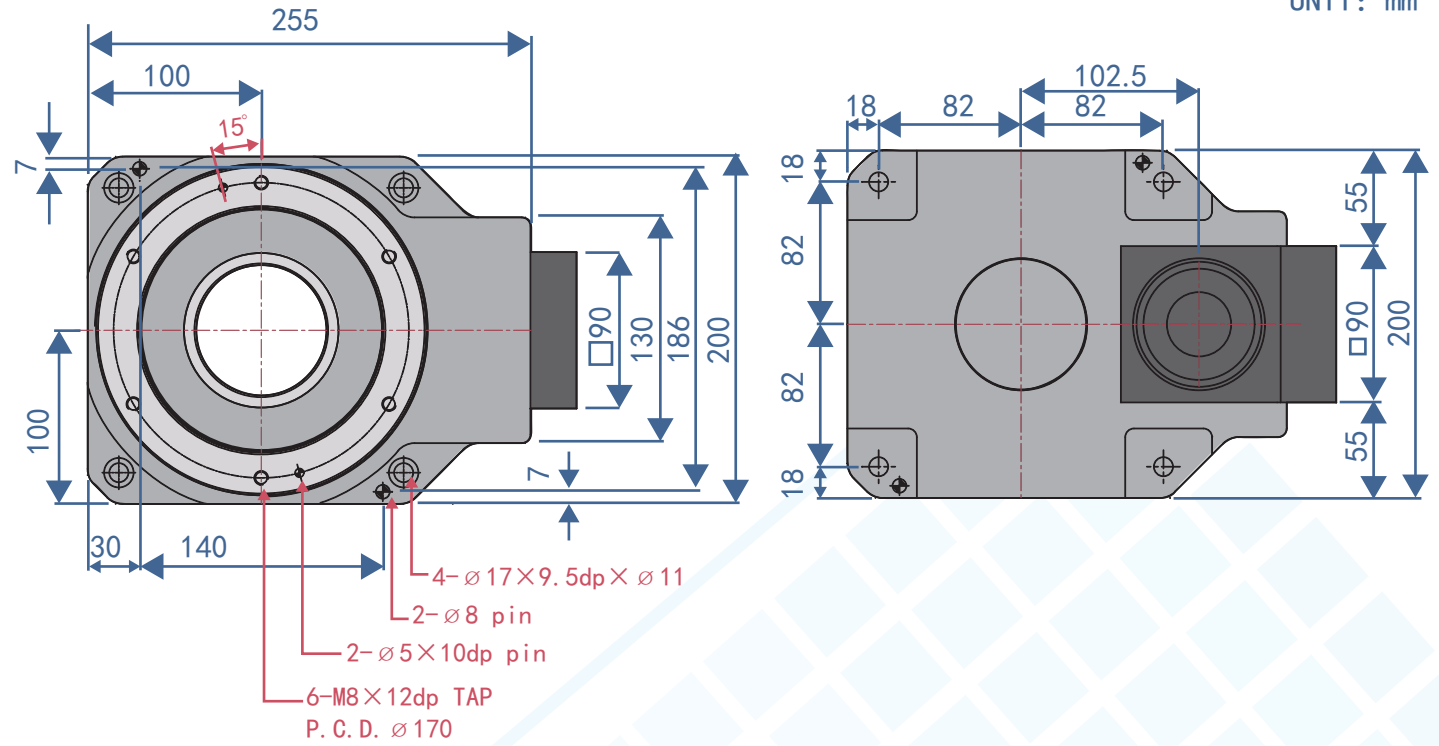

馬達固定孔
Motor mounting hole
4-M6 $\times 15dp$ TAP
P. C. D. $\varnothing 90$

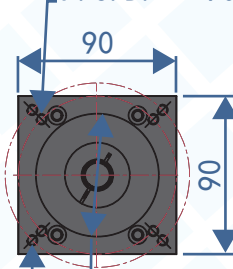

馬達凸圓
Motor flange $\varnothing 70$

馬達固定孔
Motor mounting hole
4-M6 $\times 15dp$ TAP
P. C. D. $\varnothing 105$



UNIT: mm

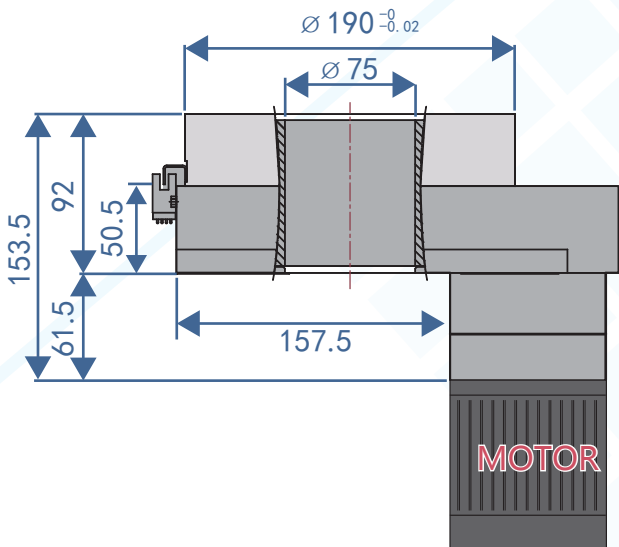
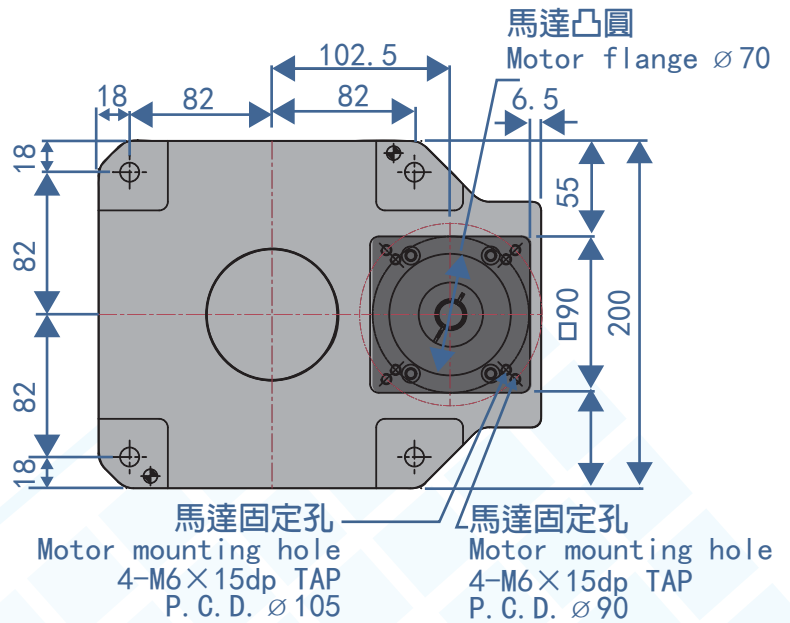
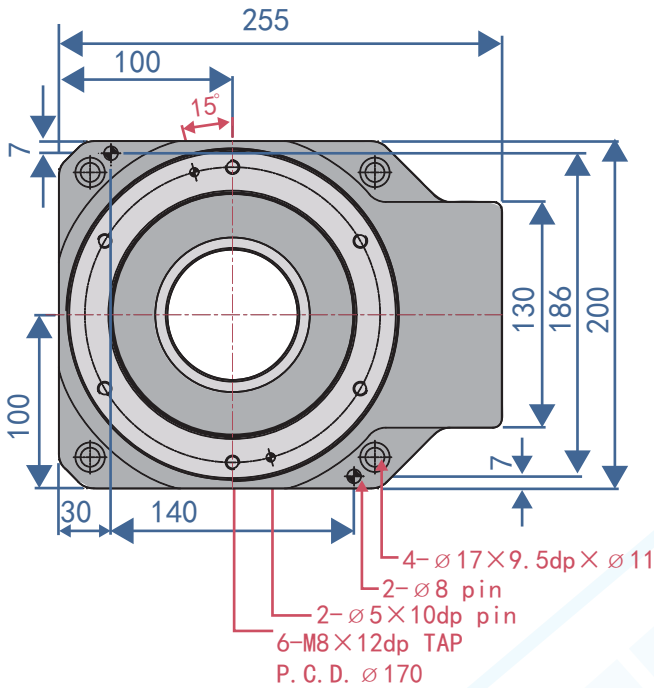

85型步進馬達定置 減速比=1:30

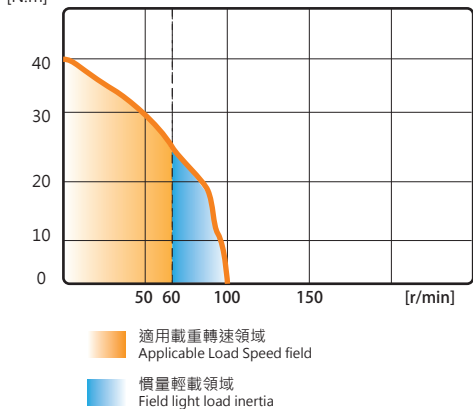

750w伺服馬達定置 減速比=1:30

